



243
T P SP

Compact,
self-pasteurizing
soft gelato machine



Performance and Quality

- **Pump feed** it is possible to obtain 40-80% overrun. Easy to adjust even when the tank is full!
- **Hard-O-Tronic®** electronic control system to choose the consistency of the soft serve in a simple manner and change it for a variety of styles of your choosing

Operations

- **The Self-Pasteurization system** allows the wash cycle to be done up to a maximum 42-day interval

Smart tools

- User-Friendly **LCD Control panel**
- Remote assistance with **Teorema** Connectivity
- **QR code** ensures updated access to the latest machine information



*optional **request them from your dealer to always keep your machine hygienically perfect.

carpigiani.com

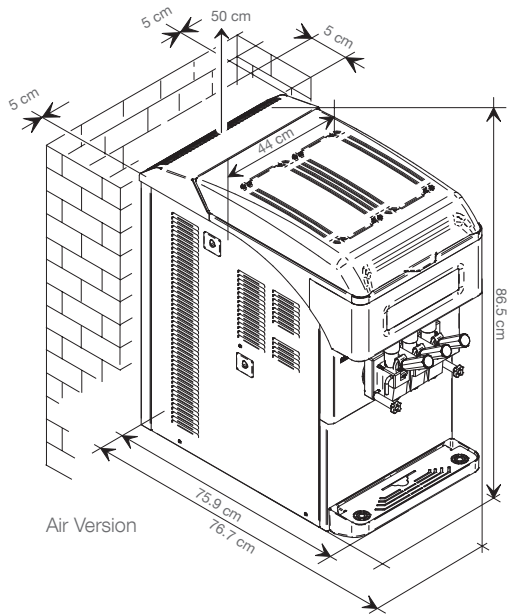

Standard configurations

- Pump
- Removable High efficiency beater in POM
- Star Door
- Self Closing
- Stainless Steel front panel
- Air-cooled
- Self-pasteurization

Optional configurations

- Nozzle
- Teorema

	Flavours	Mix Delivery System	Hourly production <i>(75 g portions)</i>	Tank Capacity <i>lt</i>	Cylinder Capacity <i>lt</i>	Rated Power Input <i>kW</i>	Fuse Size <i>A</i>	Power Supply	Cooling System	Refrigerant	Net Weight <i>kg</i>
243 T P SP	2+1	Pump	320*	5+5	1.35	3.0	20	230/50/1**	Air	R452***	190

* production capacity depends on the mix used and the room temperature ** other voltages and cycles available upon request *** alternative solutions available

243 T P SP is produced by Carpigiani with Quality System UNI EN ISO 9001.

All specifications mentioned must be considered approximate; Carpigiani reserves the right to modify, without notice, all parts deemed necessary.



Via Emilia, 45 - 40011 Anzola dell'Emilia - BOLOGNA, Italy - T. +39 051 6505111 - info@carpigiani.it

an Ali Group Company



the spirit of excellence

Ordinary Maintenance

6

12

MONTHS MONTHS

WHY IS IT NEEDED?

SUPPLIED WITH THE MACHINE



Carpi Care kit

6 MONTHS

Kit of consumable parts to keep your machine's hygiene level at the top.

Carpi Clean kit

12 MONTHS

Set of brushes of the correct size to thoroughly clean every component of the machine.

MANDATORY



Carpi Care kit

1 MONTH

Kit of consumable parts to keep your machine's hygiene level at the top. It avoids machine downtime by keeping accessible parts that can be lost or damaged during cleaning procedures handy.

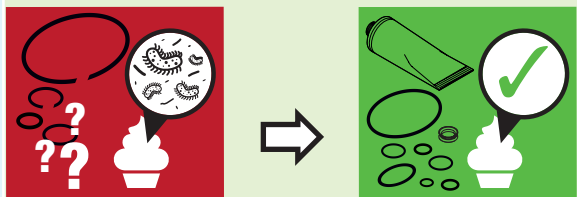

Kit of scrapers to ensure the best cooling efficiency and quality of the product. Worn scrapers increase product dispensing time and recovery time. Replacement is required every 6 months.

Ordinary Maintenance

6

12

MONTHS MONTHS

WHY IS IT NEEDED?

MANDATORY



Beater Body+Idler

-

2

Beater Body+Idler to ensure the correct functioning of the scrapers and reduce recovery time.

~ 130 sec.



RECOVERY TIME**

~ 25 sec.



Gears Set

-

1 + 1*

Set of gears to keep the pump performing at its best. If the gears are worn out, the overrun will decrease and therefore the earnings on each cup.

<20%



OVERRUN**

≥50%



RECOMMENDED



Brushes kit

1

1

Set of brushes of the correct size to thoroughly clean every component of the machine. Replacement is necessary to ensure the best cleaning and hygiene.



Carpigiani recommends a preventive maintenance visit by Carpigiani approved service providers at least once a year. *1 year or 75,000 + 75,000 servings. For correct procedure, scan QR Code on your machine. **Reported values depend on the mix used and the room temperature.